

JACKAL™

UNMANNED GROUND VEHICLE

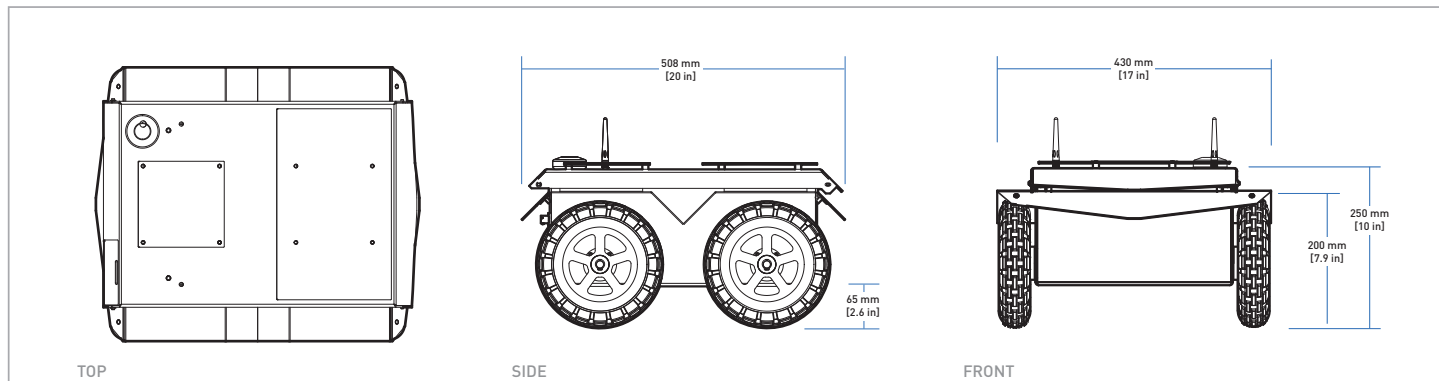

TECHNICAL SPECIFICATIONS

SIZE AND WEIGHT				
EXTERNAL DIMENSIONS (L x W x H)	508 x 430 x 250 mm (20 x 17 x 10 in)			
INTERNAL STORAGE DIMENSIONS	250 x 100 x 85 mm (10 x 4 x 3 in)			
WEIGHT	17 kg (37 lbs)			
GROUND CLEARANCE	65 mm (2.6 in)			
SPEED AND PERFORMANCE				
MAX. PAYLOAD	20 kg (44 lbs)			
ALL-TERRAIN PAYLOAD	10 kg (22 lbs)			
MAX. SPEED	2.0 m/s (6.6 ft/s)			
DRIVE POWER	500 W			
BATTERY AND POWER SYSTEM				
BATTERY CHEMISTRY	Lithium Ion			
CAPACITY	270 Watt hours			
CHARGE TIME	4 hours			
RUN TIME	Heavy usage: 2 hours Basic Usage: 8 hours			
USER POWER	5 V at 5 A, 12 V at 10 A, 24 V at 20 A			
INTERFACING AND COMMUNICATION				
CONTROL MODES	Kinematic Commands — velocity, angular velocity Open Loop Motor Driver Commands — voltage Wheel Velocity Commands			
FEEDBACK	Battery and motor current Integrated GPS receiver Wheel velocity and travel Integrated gyroscope and accelerometer			
COMMUNICATION	Ethernet, USB 3.0, RS232. (IEEE 1394 available)			
DRIVERS AND APIs	Packaged with ROS Kinetic			
INTEGRATED ACCESSORIES (included)	Wireless Game controller, GPS, IMU, On-Board Computer, WIFI Adapter, Accessory Mounting Plates			
COMPUTER	Standard	Performance		
	i3-4330TE Dual core, 2.4GHz 4 GB RAM	WIFI Adapter 120 GB Hard Drive	Intel Core i5 4570T Dual core, 2.9GHz 4 GB RAM	WIFI Adapter 128GB Hard Drive
ENVIRONMENTAL				
OPERATING AMBIENT TEMPERATURE	-20 to 45 °C (-4 to 113 °F)			
IP RATING	62 (65 available on select configurations)			

Contact us today for pricing and a free 30 minute technical assessment: 1-800-301-3863